

Hand pallet truck 2.3 ton

BT lifter

L-series

LHM230G

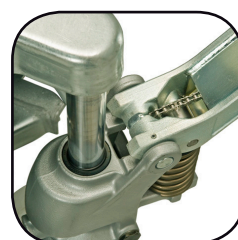

Hand pallet truck

Truck specifications					LHM230G
Identification	1.1	Manufacturer			Toyota
	1.2	Manufacturer's type designation			LHM230G
	1.4	Operator type			Hand
	1.5	Load capacity/rated load	Q(t)	kg	2300
	1.6	Load centre distance	c	mm	600
	1.8	Load distance, front axle to fork face	x	mm	945 ¹⁾
	1.9	Wheelbase	y	mm	1170 ¹⁾
Weight	2.1	Service weight		kg	63
	2.2	Axle load, with load, drive/castor/fork wheel		kg	375/805
	2.3	Axle load, without load, drive/castor/fork wheel		kg	20/10
Wheels	3.1	Steer/fork wheels: Nylon (N), Polyurethane (P), Rubber (R)			N, P, R/N, P
	3.2	Wheel size, front			175x60
	3.3	Wheel size, rear, single/bogie			85x100/85x75
	3.5	Steer wheels, number front/rear			2/2 or 2/4
	3.6	Track width, front	b ₁₀	mm	132
	3.7	Track width, rear	b ₁₁	mm	364
	Dimensions	4.4	Lift movement	h ₃	mm
		Lift height	h ₂₃	mm	200
4.9		Height of tiller in drive position, min./max.	h ₁₄	mm	1220
4.15		Height, lowered	h ₁₃	mm	85
4.19		Overall length	l ₁	mm	1510
4.20		Length to face of forks	l ₂	mm	365
4.21		Overall width	b ₁	mm	520/685
4.22		Fork dimensions	s/e/l	mm	45/156/1150 ²⁾
4.25		Width over forks	b ₅	mm	520/685
4.32		Ground clearance, centre of wheelbase	m ₂	mm	40
4.33		Aisle width for pallets 1000x1200 crossways	A _{st}	mm	1525
4.34		Aisle width for pallets 800x1200 lengthways	A _{st}	mm	1756
4.35	Turning radius	W _a	mm	1392	

1) Distance with forks raised.

2) Other fork length available: 800/910/1000/1070/1220

All data are based on table configuration. Other configurations may give other values.

Truck performance and dimensions are nominal and subject to tolerances.

Toyota Material Handling Manufacturing Sweden AB products and specifications are subject to change without notice.



Dimensional drawings

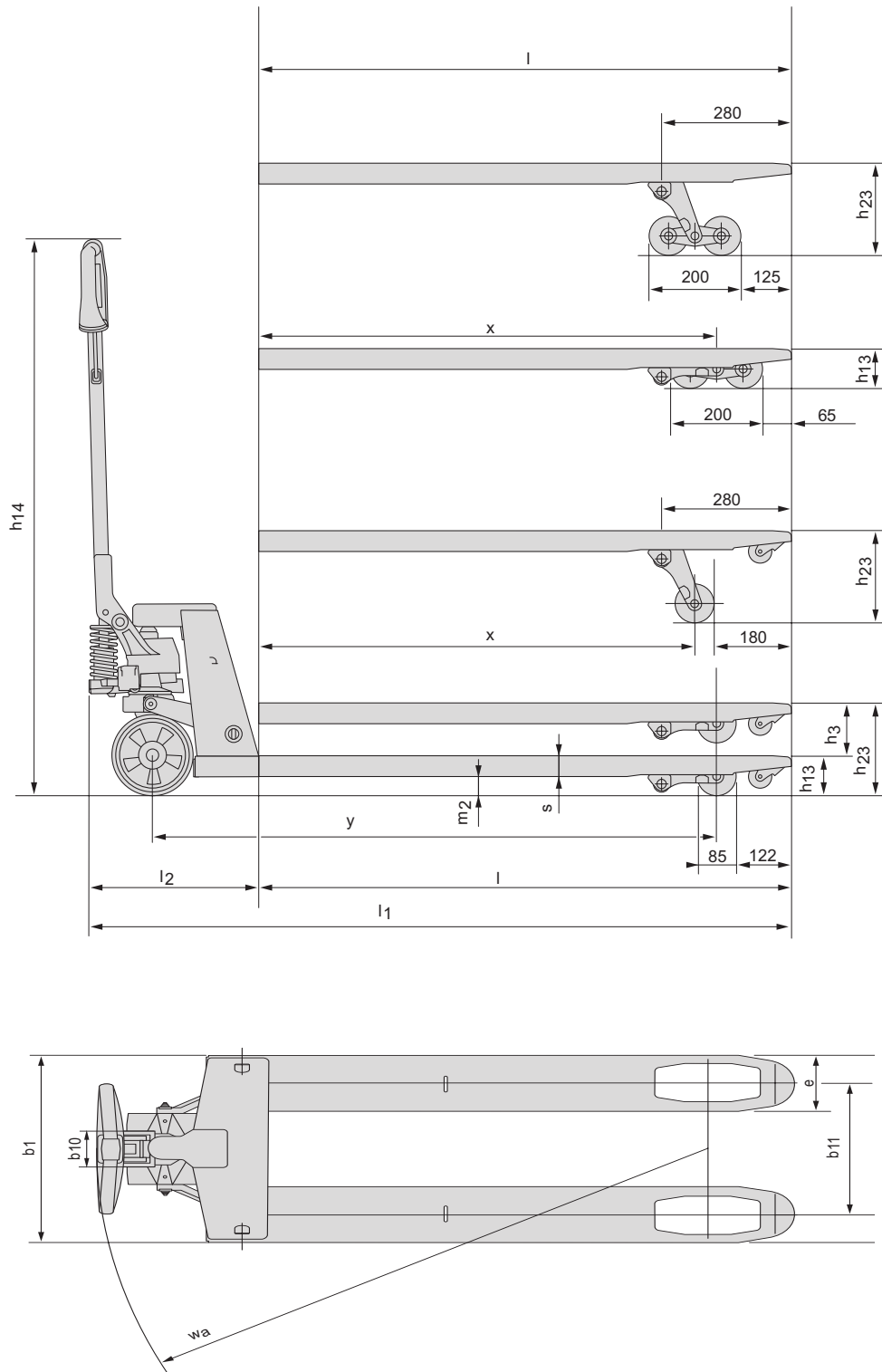



Truck features:

- The galvanized truck is a cost effective alternative for use in corrosive environments, cold rooms or cleaning room applications.
- Designed for use in cold surroundings, equipped with the BT high quality standard pump.
- Robot welding gives a high quality every time.
- Robust design and still low weight – easy to manoeuvre.
- Strong powerful thrust bearing is standard, for easier steering and enhanced durability.
- BT lowering control valve enables smooth, controlled lowering action.
- Greasable bushings ensure a long service life.
- Angled high strength polymer handle for best ergonomic grip.
- This product has been environmentally declared.
- Customized configurations – a part of our offer.



TP-Technical Publications, Sweden — 745350-040, version 2, 1202

TOYOTA

MATERIAL HANDLING

TOYOTA MATERIAL HANDLING IN EUROPE, MANAGING THE TOYOTA AND BT MATERIALS HANDLING BRANDS IN EUROPE

