



Pedestrian lowlifter truck 1.8 - 2.5 ton

BT levio

W-series

LWE180

LWE200

LWE250



Pedestrian lowlifter

Specification for lowlifter trucks					LWE180	LWE200	LWE250
Identification	1.1	Manufacturer			Toyota	Toyota	Toyota
	1.2	Model			LWE180	LWE200	LWE250
	1.3	Drive			Electric	Electric	Electric
	1.4	Operator type			Pedestrian	Pedestrian	Pedestrian
	1.5	Load capacity/rated load	Q	kg	1800	2000	2500
	1.6	Load centre	c	mm	600	600	600
	1.8	Load distance, centre of support arm wheel to face of forks (forks raised/lowered)	x	mm	898/955	898/955	898/955
	1.9	Wheelbase (forks raised/lowered)	y	mm	1287/1344	1287/1344	1287/1344
	Weight	2.1	Service weight including battery		kg	554	554
2.2		Axle load, with load, drive/castor/fork wheel		kg	760/150/1435	815/150/1580	950/150/1945
2.3		Axle load, without load, drive/castor/fork wheel		kg	260/150/135	260/150/135	260/150/135
Wheels	3.1	Drive/castor/fork wheel			Topthane/Topthane/PUR *)		Vulkollan/Topthane/Vulkollan *)
	3.2	Wheel size, front		mm	Ø230x70	Ø230x70	Ø230x70
	3.3	Wheel size, rear		mm	Ø85x75	Ø85x75	Ø85x75
	3.4	Additional wheels (dimensions)		mm	Ø125x50	Ø125x50	Ø125x50
	3.5	Wheels, number front/rear (x = driven wheels)			1x+2/4	1x+2/4	1x+2/4
	3.6	Track width, front	b ₁₀	mm	430	430	430
	3.7	Track width, rear	b ₁₁	mm	370	370	370
Dimensions	4.4	Lift	h ₃	mm	120	120	120
		Lift height	h ₂₃	mm	205	205	205
	4.8	Stand height (optional platform)	h ₇	mm	—	150	—
	4.9	Height of tiller in drive position, min./max.	h ₁₄	mm	865/1235	865/1235	865/1235
	4.15	Height, fork lowered	h ₁₃	mm	85	85	85
	4.19	Overall length	l ₁	mm	1688	1688	1688
	4.20	Length to face of forks	l ₂	mm	538	538	538
	4.21	Overall width	b ₁	mm	726	726	726
	4.22	Fork dimensions	s/e/l	mm	78/180/1150 *)	78/180/1150 *)	78/180/1150 *)
	4.25	Width over forks	b ₅	mm	550 *)	550 *)	550 *)
	4.32	Ground clearance, centre of wheelbase	m ₂	mm	21	21	21
	4.33	Aisle width for pallets 1000x1200 crossways	A _{st}	mm	1899	1899	1899
4.34	Aisle width for pallets 800x1200 lengthways	A _{st}	mm	1949	1949	1949	
4.35	Turning radius	W _a	mm	1447	1447	1447	
Performance data	5.1	Travel speed, with/without load		km/h	6/6	6/6	6/6
	5.2	Lift speed, with/without load		m/s	0,04/0,05	0,06/0,09	0,05/0,09
	5.3	Lowering speed, with/without load		m/s	0,09/0,08	0,09/0,08	0,09/0,08
	5.8	Max. gradeability, with/without load ²⁾		%	9/18 ¹⁾	9/18 ¹⁾	8/18 ¹⁾
	5.10	Service brake			Electromagnetic	Electromagnetic	Electromagnetic
Electric motor	6.1	Drive motor rating S2 60 min		kW	1,0	1,5	1,5
	6.2	Lift motor rating at S3 15%		kW	1,0 ²⁾	1,4 ²⁾	1,4 ²⁾
	6.4	Battery voltage/nominal capacity K _s		V/Ah	24/225 *)	24/225 *)	24/225 *)
	6.5	Battery weight		kg	214 *)	214 *)	214 *)
	6.6	Energy consumption acc. to VDI cycle		kWh/h	0,36	0,39	—
	8.1	Type of drive control			BT Powerdrive	BT Powerdrive	BT Powerdrive

¹⁾ Measured according to company standard

²⁾ S3 10%

*) Further alternatives are available and will produce other values.

Data is based on standard configurations: Medium battery compartment.

Truck performance and dimensions are nominal and subject to tolerances.

Toyota Material Handling Manufacturing Sweden AB products and specifications are subject to change without notice.

Battery dependent dimensions

Dimensions		Battery change		LWE180			LWE200				LWE250		
				Lift out			Lift out			Sideways	Lift out		Sideways
		Compartment	Medium	Large	DIN	Medium	Large	DIN	Large	Medium	Large	Large	
1.9	Wheelbase	y	mm	1287	1337	1297	1287	1337	1297	1337	1287	1337	1337
4.19	Overall length	l_1	mm	1688	1738	1698	1688	1738	1698	1738	1688	1738	1738
	without platform		mm	—	—	—	1773/2163	1823/2213	—	1823/2213	—	—	—
4.20	Length to face of forks	l_2	mm	538	588	548	538	588	549	599	538	588	588
	without platform		mm	—	—	—	623/1013	673/1063	—	673/1063	—	—	—
4.33	Aisle width for pallets 1000x1200 crossways	A_{st}	mm	1899	1948	1768	1899	1948	1768	1948	1899	1948	1948
	without platform		mm	—	—	—	1984/2384	2033/2433	—	2033/2433	—	—	—
4.34	Aisle width for pallets 800x1200 lengthways	A_{st}	mm	1949	1998	1968	1949	1998	1968	1998	1949	1998	1998
	without platform		mm	—	—	—	2034/2434	2083/2483	—	2083/2483	—	—	—
4.35	Turning radius	W_a	mm	1447	1496	1466	1447	1498	1466	1496	1447	1496	1496
	without platform		mm	—	—	—	1532/1932	1581/1981	—	1581/1981	—	—	—
6.4	Battery voltage, nominal capacity K_s		V/Ah	24/225	24/300	24/250	24/225	24/300	24/250	24/260	24/225	24/300	24/260
6.5	Battery weight, min.—max.		kg	180-220	220-270	180-222	180-220	220-270	180-222	220-230	180-220	220-270	220-230

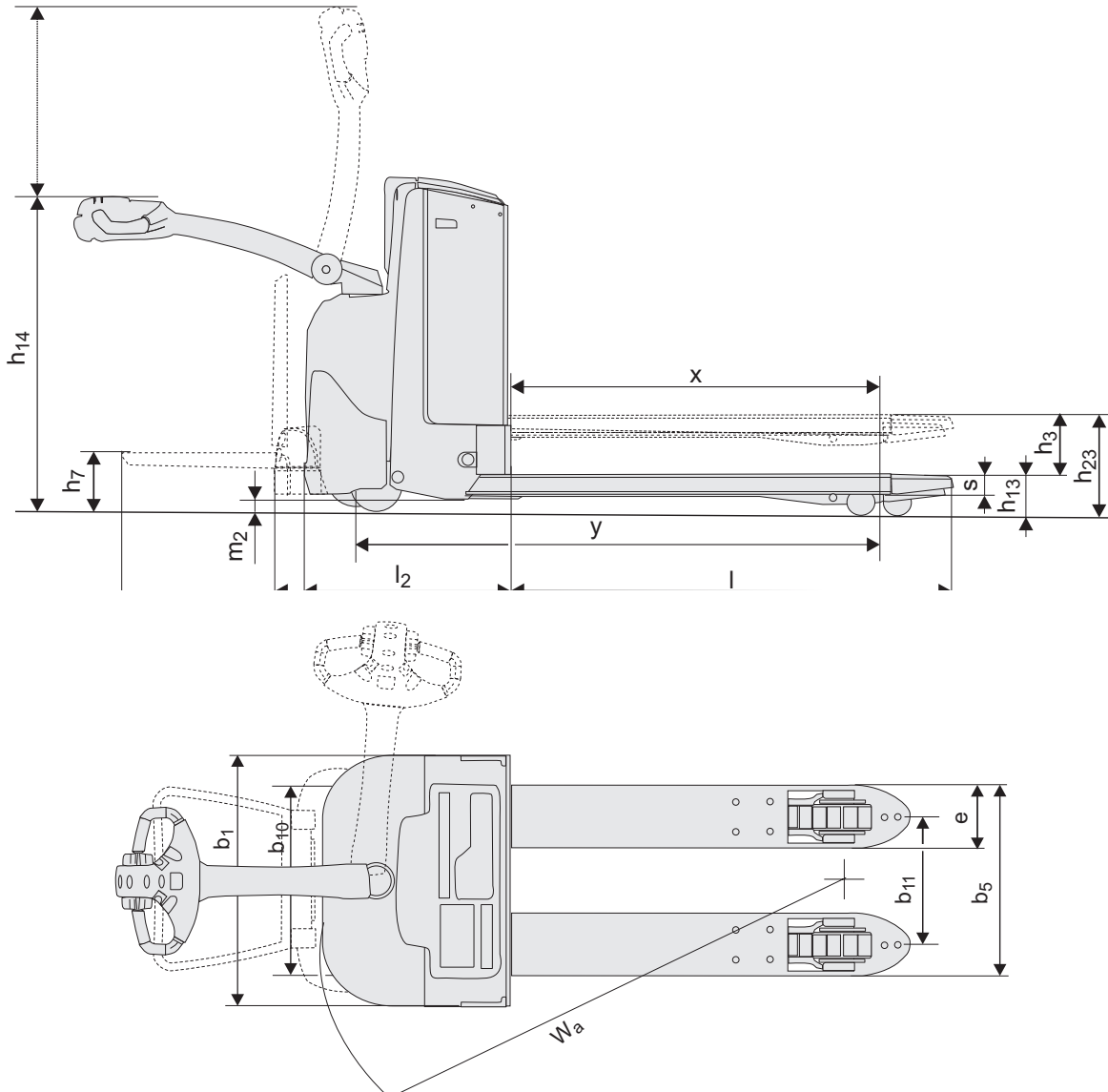



Truck features:

- BT Powerdrive System
- BT Castorlink System
- Click-2-creep
- Fingertip controls
- Temporary speed reduction - turtle button (option)
- Electronic braking system
- Electronic speed control
- Operator safety
- Storage compartments
- Automatic switch-off
- Programmable performance
- Easy access for maintenance
- Built in charger (option)
- Toyota I_site: truck fleet management system (option)
- Hydraulic oil for low temperatures
- Flip-up platform for LWE200 (option)



TP-Technical Publications, Sweden — 746892-040, version 3, 2017-01-12

TOYOTA MATERIAL HANDLING IN EUROPE, MANAGING THE TOYOTA AND BT MATERIALS HANDLING BRANDS IN EUROPE.

TOYOTA

MATERIAL HANDLING

